



City and County of San Francisco
Department of Building Inspection
1660 Mission Street, San Francisco, CA 94103

Structural Bulletin

SB 05-08

Subject: **Prequalified Connections for Special and Intermediate Steel Moment Frames for Seismic Applications**

Date: October 3, 2008

Pursuant to the San Francisco Building Code (SFBC) Section 2205.2, structural steel structures shall be designed and detailed in accordance with AISC 341-05, Part 1: *Seismic Provisions for Structural Steel Buildings*. (Note that code does allow for limited exceptions.) Further, prequalified special and intermediate steel moment frame connections are governed by AISC 358-05: *Prequalified Connections for Special and Intermediate Steel Moment Frames for Seismic Applications*. AISC 358-05 only prescribes three types of prequalified moment frame connections, including:

- Reduced beam section (RBS)
- Bolted unstiffened extended end plate (BUEEP)
- Bolted stiffened extended end plate (BSEEP)

AISC 358-05 Supplement No. 1 Draft prescribes three additional prequalified moment frame connections, including:

- Bolted flange plane (BFP)
- Welded unreinforced flange – welded web (WUF-W)
- Kaiser bolted bracket (KBB)

Because the supplement is still in draft form, these connections are not deemed to be prequalified connections by the City and County of San Francisco. Use of these non-prequalified moment frame connections shall be reviewed on a case-by-case basis with substantiating test reports conforming to AISC 341-05, Part 1, Appendix S, and will be subject to Structural Design Review (SDR) as required.

Use of proprietary connections, such as the SSDA SlottedWeb and the SidePlate connections, shall be reviewed on a case-by-case basis, and will be subject to SDR as required.

See details on page 2.

Approved: Raymond Lui, S.E.
Deputy Director for Plan Review Services

A handwritten signature in black ink, appearing to be "R. Lui", written over the printed name and title of the Deputy Director for Plan Review Services.

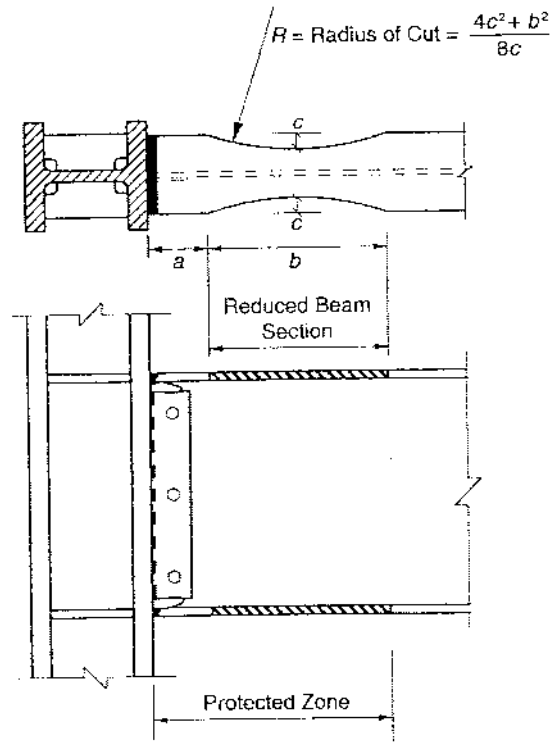

Reduced beam section connection.

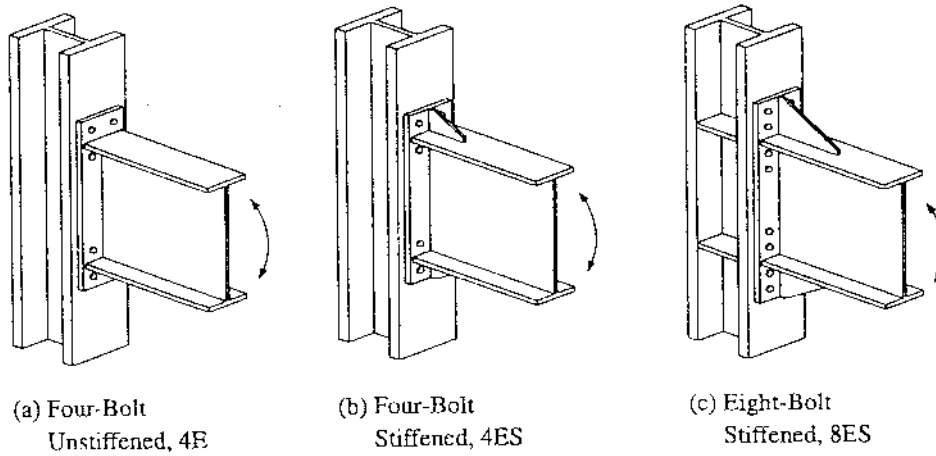

Extended end-plate configurations.